



**San Diego Unified**  
SCHOOL DISTRICT

**Graham Champion**  
Labor Compliance and Construction  
Contracts Supervision  
858-496-1902  
F - 858 496 1953

July 8, 2019

Pete Delgado  
Ferreira Construction Co, Inc.  
Dbra Ferrira Coastal Construction Co.  
10370 Commerce Center Drive, Suite B-200  
Rancho Cucamonga, CA 91730

**Via Email**  
pdelgado@ferreiraconstruction.com

Dear Mr. Delgado:

**Subject: Contract CZ-19-0619-52 JOC Fencing Services**

**Notice to Proceed No. 02 – Clay Elementary School –Joint Use Field  
Project #: 90650052**

**District Representative: Loren Chico**

This letter constitutes your notice to proceed with fencing work at Clay Elementary School per your proposal with attached scope of work breakdown sent to Loren Chico, dated May 31, 2019, for the not-to-exceed amount of \$47,041.10.

Work shall begin on July 18, 2019, and be completed no later than August 6, 2019.

Please use the site name, contract number, this NTP number on all billings and correspondence.

Original invoice should be sent to:

San Diego Unified School District  
PPO Center, Attn: Catherine Bendixen  
4860 Ruffner Street  
San Diego, CA 92111

Please call me if you have any questions regarding this NTP. Invoicing inquiries should be directed to Catherine Bendixen at (858) 627-7231.

Sincerely,

  
Graham Champion  
Labor Compliance and Facilities Contracts Supervisor

GC:mf

c: L. Jones, T. Tomovich, B. Mendoza, J. Cunningham, S. Ditto, J. Cortez, PSA



# **FERREIRA**

**DBA FERREIRA COASTAL CONSTRUCTION CO.**

SIGNATORY TO THE LABORERS, OPERATING ENGINEERS, AND TEAMSTERS UNIONS  
 License #985180  
 DIR #1000001634

BID DATE: 5/31/19

PROJECT NAME: CLAY ELEMENTARY SCHOOL- JOINT USE FIELD FENCE  
 LOCATION: 6506 SOLITA AVE, SAN DIEGO, CA 92115

PER JOB WALK CONDUCTED ON 5/17/19  
 ATTN: LOREN CHICO- DISTRICT REPRESENTATIVE

Item	Description			Total
	Provide and Install approx. 385ft of 10 ft high Chain Link Fence with Mow Band per plans			
	Provide and Install (1) 12' wide by 10' t Chain Link Double Gate			
	Provide and Install approx. 780 ft of 6 ft high Temporary Fence with stands (no shadescreen)			
	Includes all BMP's during construction			
	UNIT PRICE BOOK ITEMS, with adjustment factor( see attached)	1	LS	\$47,041.10
	See Attached:			
	Schedule, Subcontractor List, and Employee List & Certification			
			<b>Total Bid:</b>	<b>\$47,041.10</b>

**NOTE:** Field verification of Fence line layout to be verified after Utility Locating is performed

**NOTE:** Potential modification to fence line will be needed to address irrigation lines in conflict with fence line layout per as shown in plans

Thank You,

Estimator / Project Manager

\_\_\_\_\_  
 Pete Delgado

Ferreira Constructioun Co., Inc. dba  
 Ferreira Coastal Construction Co.  
 1125 Presioca Street  
 Spring Valley, CA 91977

Corporate Headquarters  
 10370 Commerce Center Dr.  
 Suite B-200  
 Rancho Cucamonga, CA 91730

Phone 909-606-5900 EXT: 683  
 Cell 909-219-0864  
 email [pdelgado@ferreiraconstruction.com](mailto:pdelgado@ferreiraconstruction.com)

2018 FENCING JOC - JOB ORDER ESTIMATE TOOL

Date: 5/31/19  
 Project: CLAY ES- JUF  
 PM: PETE DELGADO

TOTAL INCLUDING ADJUSTMENT FACTOR(S): \$ 47,041.10  
 TOTAL WITHOUT ADJUSTMENT FACTOR(S): \$ 36,688.07  
 CONTRACTOR MARKUP: \$ 12,373.03

Project: CLAY ES- JUF  
 Estimate by: PETE DELGADO  
 Estimate Date: 5/31/19

Use the filters to narrow your search. Work left to right.

Work	Material	Type	Height (feet)	Width (feet)	Post Spacing (feet)	Dimensions	Added Description	Modification	Item Number	Quantity Needed for this job (Normal)	Overtime Quantity Needed for this job (Overtime)	Holiday Quantity Needed for this job (Holiday)	Total Quantity Needed for this job	Unit of Measure	Price/Unit (adjusts based on Qty.)	Extended Cost (without Adjustment Factors)	Extended Cost (with Adjustment Factors)	COMPONENT
Provide & Install	Chain Link	Line Post	10	N/A	N/A	2.825" OD	12"x48" Ftg	N/A	67	33.00			33.00	EA	\$ 213.96	\$ 7,060.08	\$ 9,380.64	PROVIDE LINE POST FOR CHAIN LINK FENCING, 2.825" OD AND 12" DIAMETER BY 4'-0" DEEP CONCRETE FOOTING FOR 10'-0" HIGH CHAIN LINK FENCE IN SOIL WITH OR WITHOUT DG SURFACE AS DESCRIBED IN PART 2 SECTION G204001 PARA. 1.1
Provide & Install	Chain Link	Terminal Post	10	N/A	N/A	3.500" OD	14"x48" Ftg	N/A	99	4.00			4.00	EA	\$ 313.57	\$ 1,254.28	\$ 1,701.93	PROVIDE TERMINAL POST FOR CHAIN LINK FENCING, 3.500" OD AND 14" DIAMETER BY 4'-0" DEEP CONCRETE FOOTING FOR 10'-0" HIGH CHAIN LINK FENCE IN SOIL WITH OR WITHOUT DG SURFACE AS DESCRIBED IN PART 2 SECTION G204001 PARA. 1.1
Provide & Install	Chain Link	Gate Post	10	N/A	N/A	3.500" OD	14"x54" Ftg	N/A	149	2.00			2.00	EA	\$ 372.43	\$ 744.86	\$ 1,010.70	PROVIDE GATE POST FOR CHAIN LINK GATE, 3.500" OD AND 14" DIAMETER BY 4'-6" DEEP CONCRETE FOOTING FOR 10'-0" HIGH CHAIN LINK GATE IN SOIL WITH OR WITHOUT DG SURFACE AS DESCRIBED IN PART 2 SECTION G204001 PARA. 1.3
Provide & Install	Chain Link	Rail	N/A	N/A	N/A	1.660" OD	N/A	N/A	194	445.00			445.00	LF	\$ 4.13	\$ 1,837.85	\$ 2,493.78	PROVIDE RAILS FOR CHAIN LINK FENCING, TOP, AND BRACE, 1.660" OD AS DESCRIBED IN PART 2 SECTION G204001 PARA. 1.4
Provide & Install	Chain Link	Wire	N/A	N/A	N/A	N/A	N/A	N/A	200	385.00			385.00	LF	\$ 0.88	\$ 338.80	\$ 459.72	PROVIDE BOTTOM TENSION WIRE FOR CHAIN LINK FENCING AS DESCRIBED IN PART 2 SECTION G204001 PARA. 1.5
Provide & Install	Chain Link	Trust Rod	N/A	N/A	N/A	N/A	N/A	N/A	202	60.00			60.00	LF	\$ 4.27	\$ 256.20	\$ 347.64	PROVIDE TRUSS ROD FOR CHAIN LINK FENCING, INCLUDING TRUSS ROD ADJUSTMENT UNIT, AS DESCRIBED IN PART 2 SECTION G204001 PARA. 1.6
Provide & Install	Chain Link	Fabric	10	N/A	N/A	2"x2"	N/A	without slats	215	385.00			385.00	LF	\$ 18.70	\$ 7,199.50	\$ 9,769.00	PROVIDE CHAIN LINK FABRIC, 2" X 2" WITHOUT PRIVACY SLATS FOR 10'-0" HIGH CHAIN LINK FENCE AS DESCRIBED IN PART 2 SECTION G204001 PARA. 1.7
Provide & Install	Chain Link	Gate	> 6	4-8	N/A	2"x2"	Double Leaf	without slats	270	1.00			1.00	EA	\$ 1,844.31	\$ 1,844.31	\$ 2,502.54	PROVIDE CHAIN LINK GATE, DOUBLE LEAF, FOR MAINTENANCE ACCESS, WITH 2" X 2" FENCE FABRIC, OVER 6'-0" IN HEIGHT, EACH LEAF OVER 4'-0" TO 8'-0" WIDE, WITHOUT PRIVACY SLATS AS DESCRIBED IN PART 2 SECTION G204001
Provide & Install	Concrete	Mowband	N/A	N/A	N/A	N/A	8"x10"	N/A	502	385.00			385.00	LF	\$ 24.85	\$ 9,567.25	\$ 12,981.80	PROVIDE CONCRETE MOWBAND, 8" X 10", AS DESCRIBED IN PART 2 SECTION G204099 PARA. 1.1
Provide & Install	Utility Locator	N/A	N/A	N/A	N/A	N/A	N/A	N/A	510	0.75			0.75	Dwg	\$ 1,400.00	\$ 1,050.00	\$ 1,424.75	PROVIDE PROFESSIONAL UTILITY LOCATOR SERVICE (NOT DIG-ALERT) INCLUDING LOCATION AND SURFACE IDENTIFICATION OF ALL EXISTING UNDERGROUND UTILITIES AS DESCRIBED IN PART 2 SECTION G303002
Provide & Install	Temp Sanitary	N/A	N/A	N/A	N/A	N/A	N/A	N/A	513	14.00			14.00	Dwg	\$ 23.71	\$ 331.94	\$ 450.41	PROVIDE TEMPORARY SANITARY FACILITIES FOR CONSTRUCTION PERSONNEL AS DESCRIBED IN PART 2 SECTION G204001 PARA. 1.20
Provide & Install	Chain Link	Portable Fence Panel	N/A	N/A	N/A	N/A	N/A	N/A	496	780.00			780.00	LF	\$ 4.08	\$ 3,182.40	\$ 4,318.20	PROVIDE PORTABLE CHAIN LINK FENCING AS DESCRIBED IN PART 2 SECTION G204001 PARA. 1.19

**JOC – SUBCONTRACTOR LIST & CERTIFICATIONS**

Prime Contractor: Ferreira Construction Co., Inc.

Address: 1125 Presioca St., Spring Valley, CA 91977

Telephone: 909-606-5900 ext: 683 Fax: 909-606-7711

Job Order CLAY ES- JOINT USE FIELD  
 Project: \_\_\_\_\_

Complete Section A if applicable, then complete Section B as applicable:

**Section A**

All work on this project will be self-performed by the prime contractor and/or by subcontractors that were listed at the time of bid. No other subcontractors will be utilized to complete any portions of the work.

Date: 5/31/19 Signature: *Pete Delgado* Name: Pete Delgado

**Section B**

List all subcontractors of every tier who will provide services for this project.

- ✓ Column A – Provide the Subcontractor Name and contact Information
- ✓ Column B – Indicate the trade or type of services to be provided by each subcontractor.
- ✓ Column C – Indicate the contractual relationship of each subcontractor (i.e.; show which contractor hired the listed subcontractor).
- ✓ Column D – Provide the CSLB license number(s) and classification(s) for each subcontractor.
- ✓ Column E – Provide the DIR registration number for each subcontractor.
- ✓ Column F – Indicate the value of the services each subcontractor will provide expressed as a percentage of the Prime Contractor's total fee for the project.
- ✓ Column G – Indicate whether the subcontractor is a DVBE or SBE, provide the appropriate certification number or verification letter date.

[this portion left intentionally blank]

A	B	C	D	E	F	G
Subcontractor Name, Contact Person, Phone and Email address	Trade or Services to be performed for this Project	Subcontracted by: (firm name)	Subcontractor CSLB Lic. No.s & Class.	DIR Reg. No.	Subcontract % of Prime Contractor's total fixed fee	DVBE Or SBE? (letter or cert. ref)
Horeth Const. Corp. 12222 Woodside Ave., #231 Lakeside, CA 92040	Concrete Mow Band	Ferreira Const	#875607 C-8	1000006294	27%	DVBE # 2007413
Greg Horeth horeth@gmail.com						

(if additional space is needed, copy this blank sheet and attach additional sheets as needed)

## Contractor's License Detail for License # 875607

**DISCLAIMER: A license status check provides information taken from the CSLB license database. Before relying on this information, you should be aware of the following limitations.**

CSLB complaint disclosure is restricted by law (B&P 7124.6) If this entity is subject to public complaint disclosure, a link for complaint disclosure will appear below. Click on the link or button to obtain complaint and/or legal action information.

Per B&P 7071.17 , only construction related civil judgments reported to the CSLB are disclosed.

Arbitrations are not listed unless the contractor fails to comply with the terms of the arbitration.

Due to workload, there may be relevant information that has not yet been entered onto the Board's license database.

### Business Information

HORETH CONSTRUCTION CORPORATION  
9327 WHEATLANDS RD STE B  
SANTEE, CA 92071-2830  
Business Phone Number:(619) 464-2320

Entity Corporation  
Issue Date 04/05/2006  
Expire Date **04/30/2020**

### License Status

**This license is current and active.**

All information below should be reviewed.

### Classifications

C-8 - CONCRETE  
B - GENERAL BUILDING CONTRACTOR

### Bonding Information

#### Contractor's Bond

This license filed a Contractor's Bond with SURETEC INSURANCE COMPANY.

**Bond Number:** 102845

**Bond Amount:** \$15,000

**Effective Date:** 01/01/2016

Contractor's Bond History

#### Bond of Qualifying Individual

The qualifying individual GREGORY DAVID HORETH certified that he/she owns 10 percent or more of the voting stock/membership interest of this company; therefore, the Bond of Qualifying Individual is not required.

**Effective Date:** 04/05/2006

### Workers' Compensation

This license has workers compensation insurance with the EVEREST PREMIER INSURANCE COMPANY

**Policy Number:** 7600017617191

**Effective Date:** 05/05/2019

**Expire Date:** 05/05/2020

Workers' Compensation History

## Contractor Information

**Legal Entity Name**

HORETH CONSTRUCTION CORPORATION

**Legal Entity Type**

Corporation

**Status**

Expired

**Registration Number**

1000006294

**Registration effective date**

5/16/2018

**Registration expiration date**

6/30/2019

**Mailing Address**

12222 WOODSIDE AVE #231 LAKESIDE 92040 CA U...

**Physical Address**

9327 WHEATLANDS ROAD SUITE B SANTEE 92071 C...

**Email Address**
**Trade Name/DBA**

HORETH CONSTRUCTION CORPORATION

**License Number(s)**

CSLB:875607

## Registration History

Effective Date	Expiration Date
5/16/2018	6/30/2019
6/19/2017	6/30/2018
5/25/2016	6/30/2017
6/12/2015	6/30/2016
1/21/2015	6/30/2015
7/1/2019	6/30/2020

## Legal Entity Information

**Corporation Number:**

2594081

**Federal Employment Identification Number:**
**President Name:**

GEOFFREY MARTIN HORETH

**Vice President Name:**

GREGORY DAVID HORETH

**Treasurer Name:**

GREGORY DAVID HORETH

**Secretary Name:**

GREGORY DAVID HORETH

**CEO Name:**

GEOFFREY MARTIN HORETH

**Agent of Service Name:**

GREGORY DAVID HORETH

**Agent of Service Mailing Address:**

11531 PINEHURST DRIVE LAKESIDE 92040 CA United States of America



## Workers Compensation

Do you lease employees through Professional Employer Organization (PEO)?:

Please provide your current workers compensation insurance information below:

	PEO	PEO	PEO
PEO InformationName	Phone	Email	

Insured by Carrier

**Policy Holder Name:**HORETH CONSTRUCTION CORPORATION**Insurance Carrier:** EVEREST NATIONAL INSURANCE COMPANY**Policy Number:**7600017617181  
**Inception date:**5/4/2018**Expiration Date:**5/4/2019

## Contractor Information

**Legal Entity Name**  
HORETH CONSTRUCTION CORPORATION

**Legal Entity Type**  
Corporation

**Status**  
Expired

**Registration Number**  
1000006294

**Registration effective date**  
6/19/2017

**Registration expiration date**  
6/30/2018

**Mailing Address**  
12222 WOODSIDE AVE #231 LAKESIDE 92040 CA U...

**Physical Address**  
9327 WHEATLANDS ROAD SUITE B SANTEE 92071 C...

**Email Address**

**Trade Name/DBA**  
HORETH CONSTRUCTION CORPORATION

**License Number(s)**  
CSLB:875607

## Registration History

Effective Date	Expiration Date
5/16/2018	6/30/2019
6/19/2017	6/30/2018
5/25/2016	6/30/2017
6/12/2015	6/30/2016
1/21/2015	6/30/2015
7/1/2019	6/30/2020

**Prime Contractor's Certifications:**

As the prime contractor for this project and in accord with Agreement No. **CZ19-0619-52** for Job Order Contracting (JOC) services, I hereby certify under penalty of perjury the following:

1. This is a complete and true list of all subcontractors of every tier to be employed to provide services in connection with this project.
2. The information provided herein is accurate to the best of my ability to provide at this time.
3. I have verified that each subcontractor possesses the appropriate licenses and credentials required to perform the specified construction services.
4. I am aware that no subcontractor substitutions may be made without at least seven days advance notice to the District and all subcontractor substitutions must be reviewed and approved by the District in advance.
5. I may use subcontractors that are not listed at the time the job order is issued only if the work to be performed under that job order is less than ten thousand dollars (\$10,000).
6. All services subcontracted for this project were obtained through the solicitation and selection process prescribed in Public Contract Code (PCC) Chapter 4 (commencing with Section 4100) of Part 1, and section 20919.26 including, but not limited to, the following:
  - a. Provide public notice of the availability of work to be subcontracted by trade. The public notice shall include the scope of work; the project location; the name, address, and the telephone number of the primary job order contractor; and the closing date, time, and location for sealed bids to be submitted.
  - b. The primary job order contractor shall take sealed bids from the subcontractors solicited for the proposal. These bids shall be publicly opened at a prescribed time and place by the primary job order contractor. After the bids are opened, the job order contractor shall notify the school district which subcontractor was selected.
  - c. The notification shall include every subcontractor for all tiers and must establish the authorized subcontractor list for the job order. Work shall not commence prior to seven days' notice of the established subcontractor list and the subsequent addition of any subcontractor to the job order.
  - d. The notification shall identify the scope of the work to be performed by each subcontractor to the job order, broken down by craft. If a subcontractor performs multiple crafts, the job order contractor shall identify the work of each craft to be performed.
7. I am aware that if the school district determines that there has been a violation of Chapter 4 of the PCC (commencing with Section 4100) of Part 1, including bid shopping by the primary job order contractor, the school district may terminate the job order or the contractor may lose authorization to proceed with awarded work subject to the school district's administrative due process review, if such review is established pursuant to the school district's project labor agreement. If the school district determines that a job order contractor has violated any provision set forth in Chapter 4 (commencing with Section 4100) of Part 1, the school district may declare the contractor ineligible for future job orders and may result in a loss of prequalification status for a period of time to be determined by the school district.
8. Certification of DVBE Status. Contractor certifies, warrants and represents to the District that the Contractor has exercised due diligence in ascertaining the status of each proposed DVBE identified above as a DVBE in compliance with the applicable provisions of the District's DVBE Participation Program Policy and applicable law. By executing and submitting this certification, Contractor represents to the District that each DVBE identified is duly and properly certified as a DVBE in conformity with the District's DVBE Program Policy and applicable law. Contractor acknowledges that in the event that the District shall reasonably determine that any DVBE identified is not duly and properly certified in the appropriate category of DVBE, the Job Order may be rejected or canceled by the District. For each DVBE identified, Contractor has submitted with its Job Order Proposal forms of DVBE Certification duly completed and executed by each such DVBE.

Printed name: Pete Delgado

Position: Project Manager

Signature: \_\_\_\_\_

*Pete Delgado*

Date: 5/31/19

LIST OF EMPLOYEES

Prime Contractor: Ferreira Construction Co., Inc.  
 Address: 1125 Presioca St., Spring Valley, CA 91977  
 Telephone: 909-606-5900, ext:683 Fax: 909-606-7711  
 Job-Order Project: CLAY ES- JUF

The following is a list of our employees and our subcontractor's employees and their DOJ fingerprinting status who will be working on the project site(s). I will keep this list current and send the District's Construction Manager any new updates with my monthly payment application.

<u>NAME and TITLE</u>	<u>EMPLOYER</u>	<u>FINGERPRINTED?</u>	
		<u>Yes</u>	<u>No</u>
<u>Joe Sedano- Foreman</u>	<u>Ferriera Construction</u>	<u>X</u>	<u>    </u>
<u>Christian Sedano- Appr.</u>	<u>Ferriera Construction</u>	<u>X</u>	<u>    </u>
<u>Jose Arellano-Laborer</u>	<u>Ferriera Construction</u>	<u>X</u>	<u>    </u>
<u>Jorge Arellano-Laborer</u>	<u>Ferriera Construction</u>	<u>X</u>	<u>    </u>
<u>Fernando Velasco-General Foreman- Ferreira Const</u>	<u>    </u>	<u>X</u>	<u>    </u>
<u>    </u>	<u>    </u>	<u>    </u>	<u>    </u>
<u>    </u>	<u>    </u>	<u>    </u>	<u>    </u>
<u>    </u>	<u>    </u>	<u>    </u>	<u>    </u>
<u>    </u>	<u>    </u>	<u>    </u>	<u>    </u>
<u>    </u>	<u>    </u>	<u>    </u>	<u>    </u>
<u>    </u>	<u>    </u>	<u>    </u>	<u>    </u>
<u>    </u>	<u>    </u>	<u>    </u>	<u>    </u>
<u>    </u>	<u>    </u>	<u>    </u>	<u>    </u>
<u>    </u>	<u>    </u>	<u>    </u>	<u>    </u>
<u>    </u>	<u>    </u>	<u>    </u>	<u>    </u>
<u>    </u>	<u>    </u>	<u>    </u>	<u>    </u>
<u>    </u>	<u>    </u>	<u>    </u>	<u>    </u>

Pete Delgado  
 Contact Name (Officer or Employee)  
*Pete Delgado*  
 Authorized Signature  
909-606-5900 ext: 683  
 Telephone Number

Project Manager  
 Title

**CONTRACTOR CERTIFICATION REGARDING BACKGROUND CHECKS**

Ferreira Construction Co., Inc. certifies that it has performed one of the following:  
Name of Contractor/Consultant

Pursuant to Education Code Section 45123.1, Contractor has conducted criminal background checks, through the California Department of Justice, of all employees providing services to the San Diego Unified School District, pursuant to contract the contract listed in the header above, and that none have been convicted of serious or violent felonies, as specified in Penal Code 1192.7(c) and 667.5(c), respectively.

OR

Pursuant to Education Code Section 45125.2, Contractor will ensure the safety of pupils by one or more of the following methods:

1) The installation of a physical barrier at the worksite to prevent contact with pupils (i.e. 8 foot chain link fencing).

AND

2) Continual supervision and monitoring of all employees of the entity by an employee of the entity, such as foremen, whom the Department of Justice has ascertained has not been convicted of a violent or serious felony.

OR last 4 digits of SSI#-2425 -Joe Sedano

3) Will execute the required Department of Justice application and send either all employees or supervising and monitoring employees for fingerprinting at an authorized processing center. ***Prior to performing work on site Contractor must provide certification that the required employees have been fingerprinted.***

Contact [www.oag.ca.gov](http://www.oag.ca.gov) to obtain an ORI number or more information from the Department of Justice regarding this requirement.

AND

As further required by Education Code Section 45125.1, attached hereto as "Attachment A" is a list of the names of the employees of the undersigned who will be working on the project and who, to the best knowledge of the undersigned, are not convicted felons or awaiting trial for a felony charge.

I declare under penalty of perjury under the laws of the State of California that the foregoing is true and correct.

Date: 5/31/, 2019

*Pete Delgado*

Signature

PROJECT MANAGER

Title

- ⊗ RE-SHAFTED PART CIRCLE ROTARY POP-UP LAWN HEAD
- ⊕ RE-SHAFTED PART CIRCLE ROTARY POP-UP LAWN HEAD
- ⚡ RE-RUNTE CONGR. W/ (ELECTRIC)
- ⊕ RIGHT VALVE
- ⊕ REGRASS COUPLING VALVE
- ⊕ REPAVE BOX
- 1 PROPOSED KEYNOTES

**PROPOSED KEYNOTES**

- 1 REMOVE 10' OF 6" GALVANIZED CHAIN LINK WITH GALVANIZED 2" CHAIN LINK CLOSURE. ALL CHAIN LINK SHALL BE SUPPLIED BY SAN DIEGO PARKS & RECREATION'S STAYSAFE® OF THE LINKS. PROVIDE PAIR OF 10'x10' CHAIN LINK GATE WITH GALVANIZED 2" CHAIN LINK FABRIC. SEE ELEVATION 24-27.
- 2 REMOVE 10' OF 6" GALVANIZED CHAIN LINK WITH GALVANIZED 2" CHAIN LINK CLOSURE. ALL CHAIN LINK SHALL BE SUPPLIED BY SAN DIEGO PARKS & RECREATION'S STAYSAFE® OF THE LINKS. PROVIDE PAIR OF 10'x10' CHAIN LINK GATE WITH GALVANIZED 2" CHAIN LINK FABRIC. SEE ELEVATION 24-27.
- 3 REMOVE 10' OF 6" GALVANIZED CHAIN LINK WITH GALVANIZED 2" CHAIN LINK CLOSURE. ALL CHAIN LINK SHALL BE SUPPLIED BY SAN DIEGO PARKS & RECREATION'S STAYSAFE® OF THE LINKS. PROVIDE PAIR OF 10'x10' CHAIN LINK GATE WITH GALVANIZED 2" CHAIN LINK FABRIC. SEE ELEVATION 24-27.
- 4 REMOVE 10' OF 6" GALVANIZED CHAIN LINK WITH GALVANIZED 2" CHAIN LINK CLOSURE. ALL CHAIN LINK SHALL BE SUPPLIED BY SAN DIEGO PARKS & RECREATION'S STAYSAFE® OF THE LINKS. PROVIDE PAIR OF 10'x10' CHAIN LINK GATE WITH GALVANIZED 2" CHAIN LINK FABRIC. SEE ELEVATION 24-27.
- 5 REMOVE POST
- 6 REMOVE OPENING

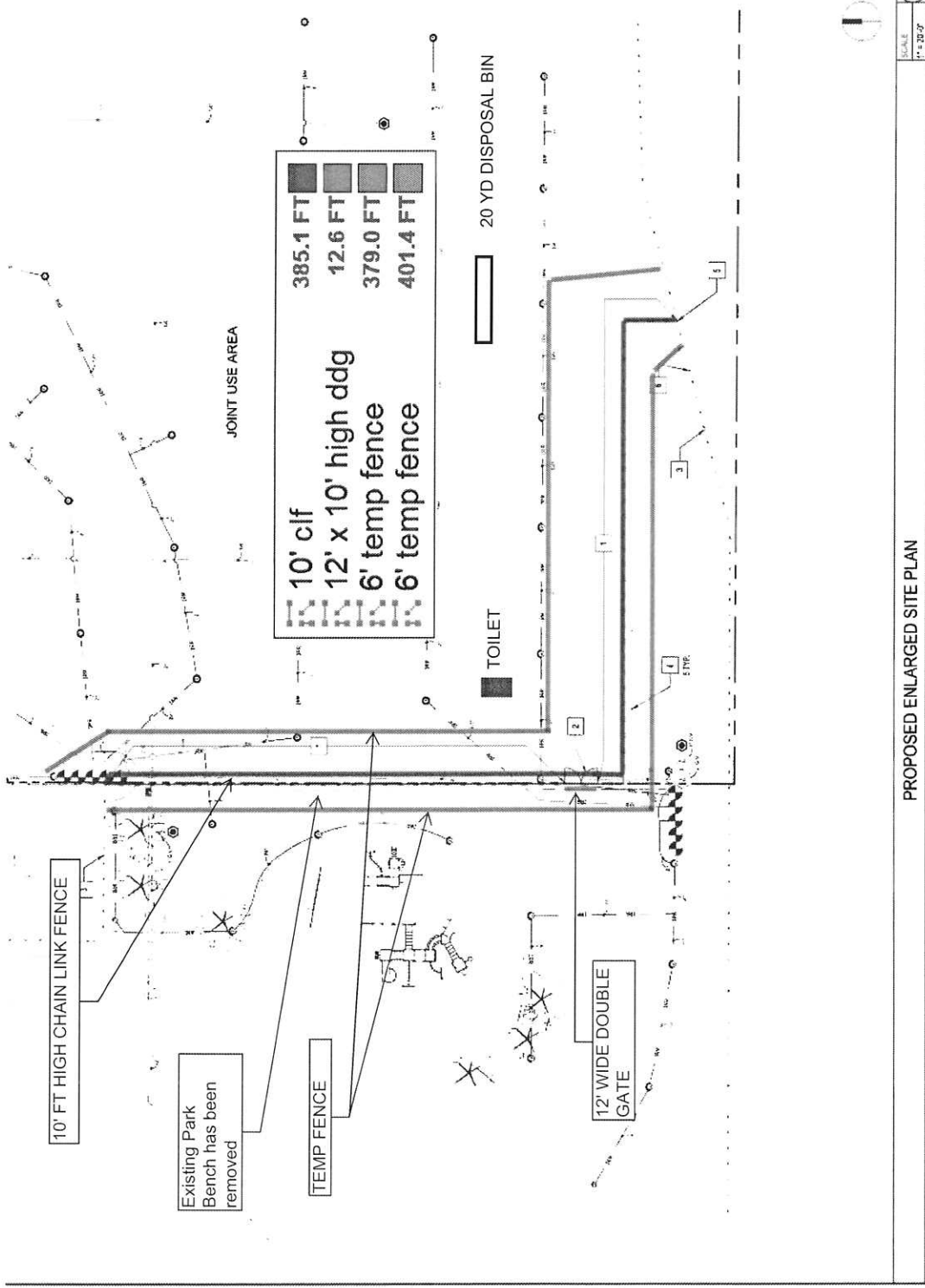



## CLAY ES- JOINT USE FIELD FENCE

JOC CONTRACTOR  
FERREIRA CONSTRUCTION

## CHAINLINK FENCE/GATES SUBMITTAL

DATE: 6/3//19

### ACTION SUBMITTALS

1. CHAINLINK FENCE DETAIL- ( 10 FT)
2. CHAINLINK GATE DETAILS- (DOUBLE)
3. MISC FENCE/GATE HARDWARE
4. MOW BAND DETAIL
5. 6' TEMP FENCE DETAIL
- 6, CLAY ES SITE UTILIZATION PLAN

# CHAIN-LINK FENCE DETAIL

10 to 12 ft Fabric Height, Top Rail with Brace Assembly  
Not to Scale

15/8 P.S. Rail Assembly  
10'-0" 1/4" max. spacing, o.c.

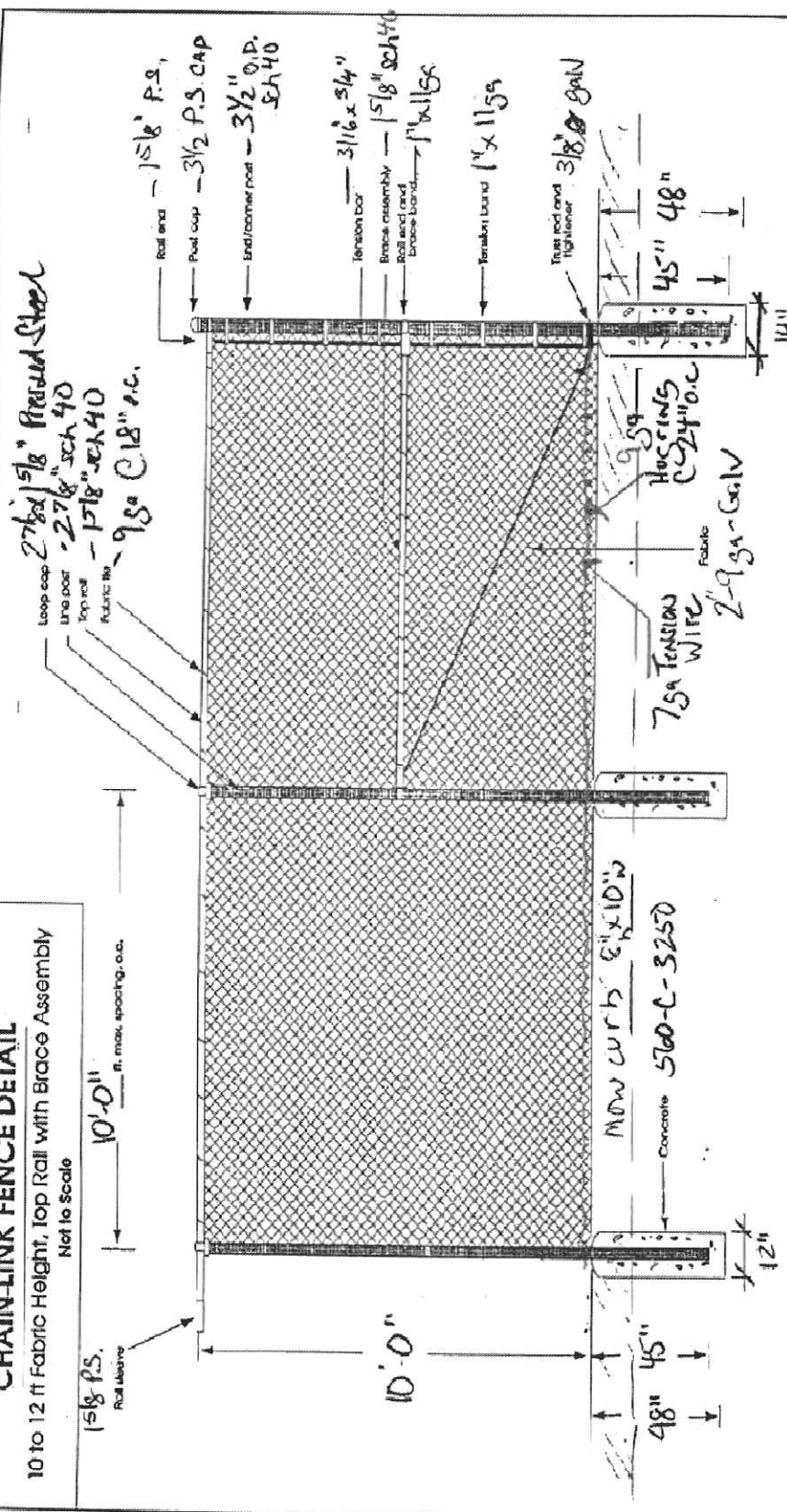

PROJECT: CLAY ES. JOINT USE FIELD  
 OWNER: FERRERA  
 SUBMITTED BY: FERRERA  
 DATE: 6/1/19  
 DRAWING NO.: CLF .15  
 GENERAL CONTRACTOR: FERRERA CONST.

All materials are salvaged

Fabric	Height	Mean	Grade	Spacing	Finish	Note
	0"	2 1/8"	9 Ga	1 1/2"	Galv	Length
Framework	0"	0"	1 1/2"	1 1/2"	Galv	
End/corner post	3 1/2"	3 1/2"	2 1/2"	2 1/2"	7.58	
Line post	2 7/8"	2 7/8"	2 1/2"	2 1/2"	5.78	
Rail	1 5/8"	1 5/8"	2 1/2"	2 1/2"	3.27	

TYPICAL 10 FT CHAIN LINK FENCE DETAIL - TOP RAILS/BRACE RAILS

POSTS	SIZE	WALL	TYPE	FINISH	CONCRETE: 560-C-3200 CITY OF SD MIX	FENCE MATERIALS
END/CORNER POSTS	3-1/2" O.D.	SCH 40	GALV	GALVANIZED		FABRIC
LINE POSTS	2-7/8" O.D.	SCH 40	GALV	GALVANIZED		TENSION/BRACE BNDS
RAILS/BRACES	1-5/8" O.D.	SCH 40	GALV	GALVANIZED		TENSION BARS
PROJECT:	CLAY ES-JOINT USE FIELD FENCE					SUBMITTED TO:
JOC CONTRACTOR:	FERRERA CONSTRUCTION					SUBMITTED BY:
OWNER:	SAN DIEGO UNIFIED SCHOOL					DATE:
						SCALE:
						NTS



SAN DIEGO UNIFIED SCHOOL DISTRICT  
 FERRERA CONSTRUCTION  
 PETE DELGADO  
 6/3/2019

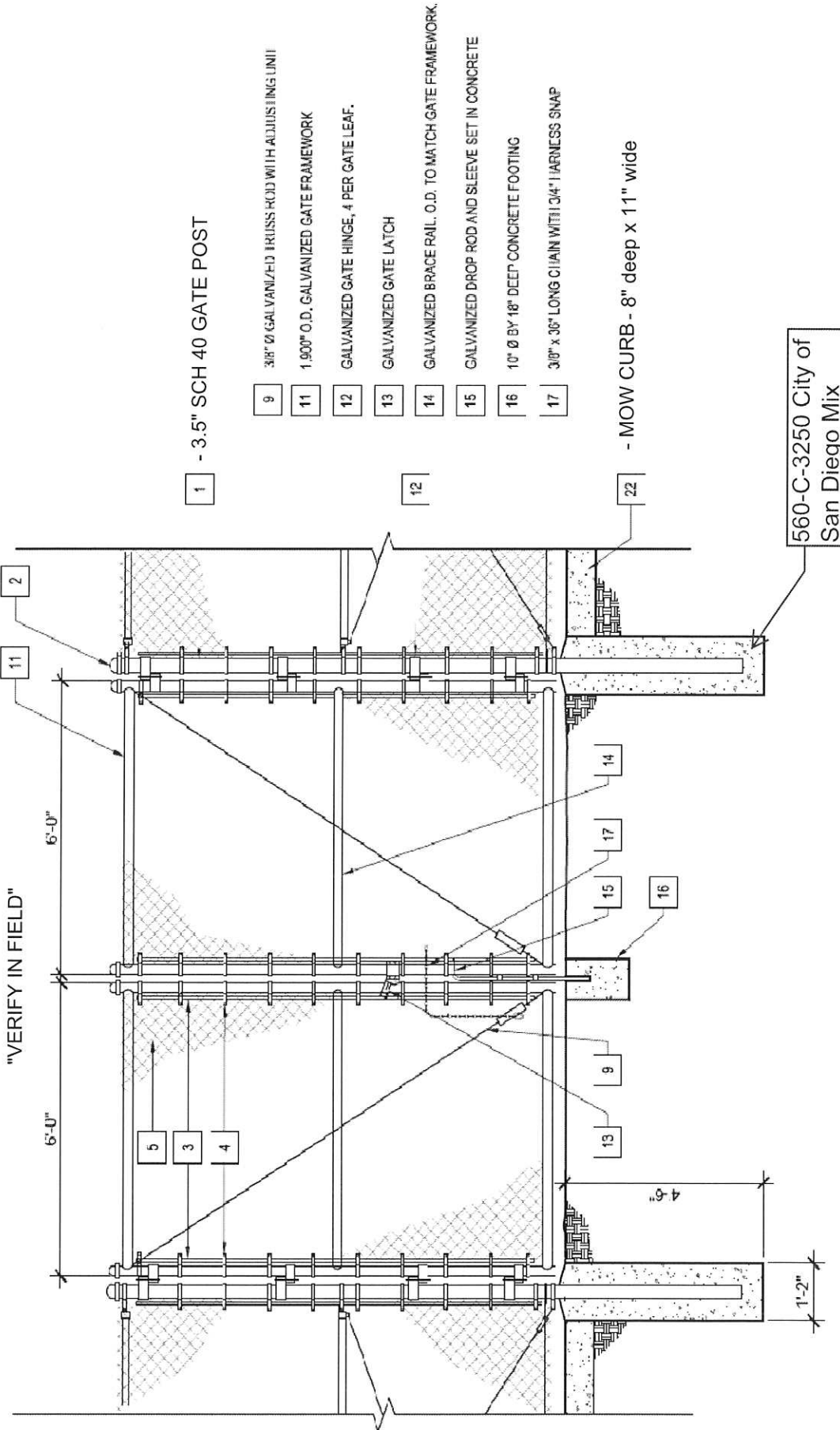

1 - 3.5" SCH 40 GATE POST

- 9 3/8" Ø GALVANIZED BRUSS ROD WITH ADJUSTING UNIT
- 11 1.900" O.D. GALVANIZED GATE FRAMEWORK
- 12 GALVANIZED GATE HINGE, 4 PER GATE LEAF.
- 13 GALVANIZED GATE LATCH
- 14 GALVANIZED BRACE RAIL. O.D. TO MATCH GATE FRAMEWORK.
- 15 GALVANIZED DROP ROD AND SLEEVE SET IN CONCRETE
- 16 10" Ø BY 18" DEEP CONCRETE FOOTING
- 17 3/8" x 36" LONG CHAIN WITH 1/4" HARNES SNAP

22 - MOW CURB - 8" deep x 11" wide

560-C-3250 City of San Diego Mix

"VERIFY IN FIELD"

TYPICAL 10 FT HIGH DOUBLE SWING GATE DETAIL

POSTS	SIZE	WALL	TYPE	FINISH	FENCE MATERIALS
GATE POSTS	3.5" OD	SCH 40	GALV	GALVANIZED	FABRIC
RAILS/BRACES	1-5/8" O.D.	SCH 40	GALV	GALVANIZED	HINGES
PROJECT:	CLAY ES-JOINT USE FIELD FENCE				2"-9 GA - GAW- KK
JOC CONTRACTOR:	FERREIRA CONSTRUCTION				180 DEGREE INDUSTRIAL HINGES
OWNER:	SAN DIEGO UNIFIED SCHOOL				1-3/8" PIPE WITH GUIDES AND FORK
					3/8" X 36" GALV CHAIN, WITH HARNES SNAP
					SAN DIEGO UNIFIED SCHOOL DISTRICT
					SUBMITTED TO:
					SUBMITTED BY:
					DATE:
					SCALE:



NTS



# Industrial 180 Degree Hinge Assembly

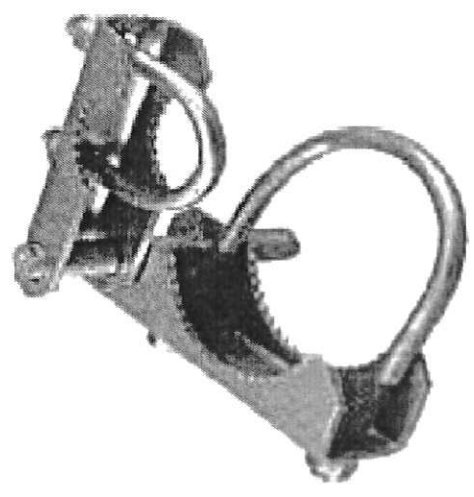

# Industrial Guide & Latch Assembly

(Assembly Includes 1 Fork + Guides w/ Bolts and 5/16 x 2" Hold-Up Pin)

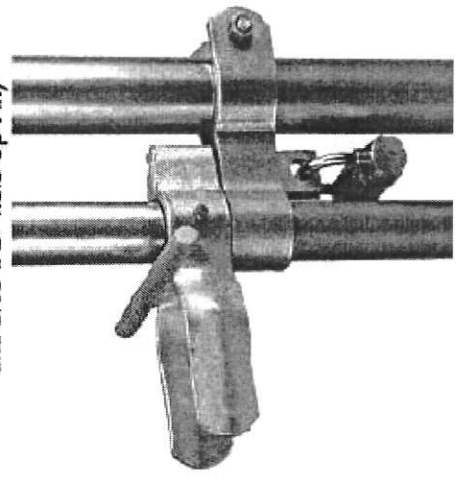

## MISC FENCE/GATE HARDWARE

POSTS	CONCRETE: 560-C-3200 CITY OF SD MIX	FENCE MATERIALS	2"-9 GA - GAW- KK
GATE POSTS		FABRIC	180 DEGREE INDUSTRIAL HINGES
		IND. DROP ROD	1-3/8" PIPE WITH GUIDES AND FORK
PROJECT:	CLAY ES JOINT USE FIELD	SUBMITTED TO:	SAN DIEGO UNIFIED SCHOOL DISTRICT
JOC CONTRACTOR:	FERREIRA CONSTRUCTION	SUBMITTED BY:	FERREIRA CONSTRUCTION PETE DELGADO
OWNER:	SAN DIEGO UNIFIED SCHOOL	DATE:	6/3/2019
		SCALE:	NTS



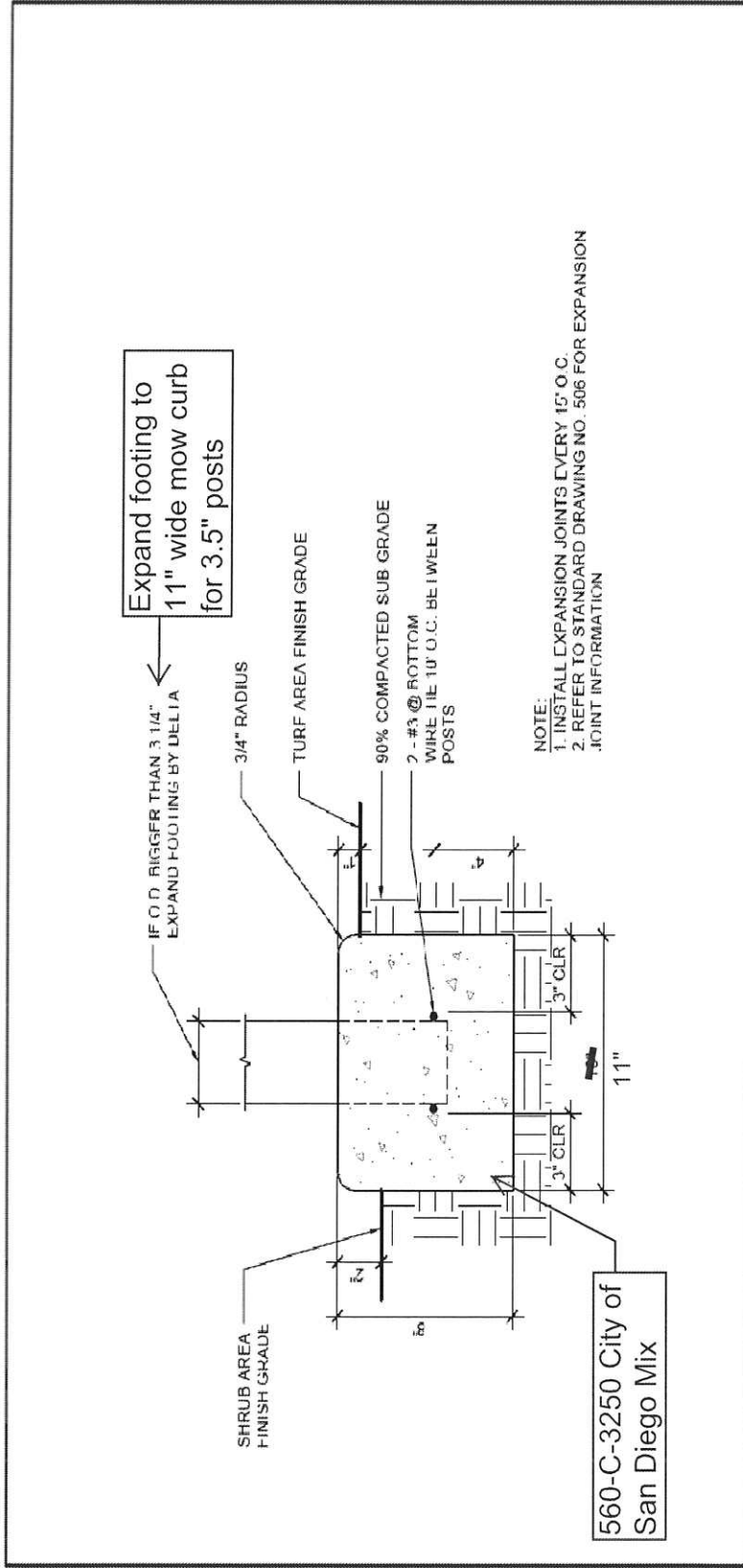

Expand footing to 11" wide mow curb for 3.5" posts

560-C-3250 City of San Diego Mix

NOTE:  
 1. INSTALL EXPANSION JOINTS EVERY 15' O.C.  
 2. REFER TO STANDARD DRAWING NO. 506 FOR EXPANSION JOINT INFORMATION

REVISIONS	DATE	BY	DATE	BY	DATE	BY

**CONCRETE MOW CURB**

PROJECT NO.	517
SHEET NO.	OF 1 SHEETS
DATE	03/05/2019
FILE NAME	(S:\2019\03\05\517.dwg)
DRAWN	SM
CHECKED	TC



**CONCRETE MOW CURB**

POSTS	SIZE	WALL	TYPE	FINISH
END/CORNER POSTS	3.5" O.D.	SCH 40	GALV	GALVANIZED
LINE POSTS	2-7/8" O.D.	SCH 40	GALV	GALVANIZED
PROJECT:	CLAY ES- JOINT USE FIELD FENCE			
JOC CONTRACTOR:	FERREIRA CONSTRUCTION			
OWNER:	SAN DIEGO UNIFIED SCHOOL DISTRICT			
MATERIALS	CONCRETE			
REBAR	# 3 REBAR			
SUBMITTED TO:	SAN DIEGO UNIFIED SCHOOL DISTRICT			
SUBMITTED BY:	FERREIRA CONSTRUCTION			
DATE:	6/3/2019			
SCALE:	NTS			



**TEMPORARY PANELS**  
Half-Bent Frame w/  
Welded Bottom

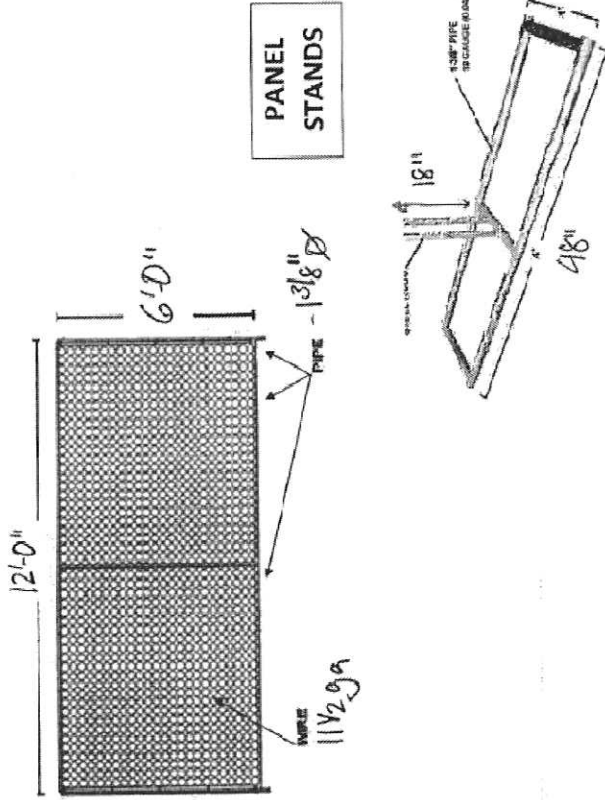

TEMP FENCE PANEL DETAIL

FRAME	SIZE	WALL	TYPE	FINISH	FENCE MATERIALS
1-3/8" PIPE FRAME	1-3/8"	16 GA	GALV	GALVANIZED	FABRIC
STANDS	1-3/8"	16 GA	GALV	GALVANIZED	STEEL RODS
PROJECT:	CLAY ES- JOINT USE FIELD FENCE				2-1/4" - 11-1/2" GA - GBW - K/K
JOC CONTRACTOR:	FERREIRA CONSTRUCTION				1" ROUND BY 18" HIGH
OWNER:	SAN DIEGO UNIFIED SCHOOL DISTRICT				SAN DIEGO UNIFIED SCHOOL DISTRICT
	SUBMITTED TO:				FERREIRA CONSTRUCTION
	SUBMITTED BY:				PETE DELGADO
	DATE:				6/3/2019
	SCALE:				NTS



(1) REFLECTOR PART CIRCLE AND RAY FOR UP LAMP HEAD  
 (2) REFLECTOR PART CIRCLE AND RAY FOR DOWN LAMP HEAD  
 (3) REFLECTOR CONTROL VALVE (ELECTRIC)  
 (4) REFLECTOR VALVE  
 (5) REFLECTOR COUPLING VALVE  
 (6) REFLECTOR  
 (7) PROPOSED KEYNOTES

**PROPOSED KEYNOTES**  
 1 PROVIDE 10' HIGH GALVANIZED CHAIN LINK FENCE WITH GALVANIZED 2 1/2" CHAIN LINK FABRIC AND 1/2" GALVANIZED RIGID 1 1/2" DIA. 3" X 30" FEED VERY MINUTE TACT. ANCHORS TO FACE OF IN-TOWN CURB.  
 2 PROVIDE PART OF IN-TOWN CHAIN LINK GATE WITH GALVANIZED 2 1/2" CHAIN LINK FABRIC. SEE ELEVATION 24.32'.  
 3 10' CHAIN LINK FENCE  
 4 REFLECTOR POST  
 5 REFLECTOR POST  
 6 REFLECTOR OPENING

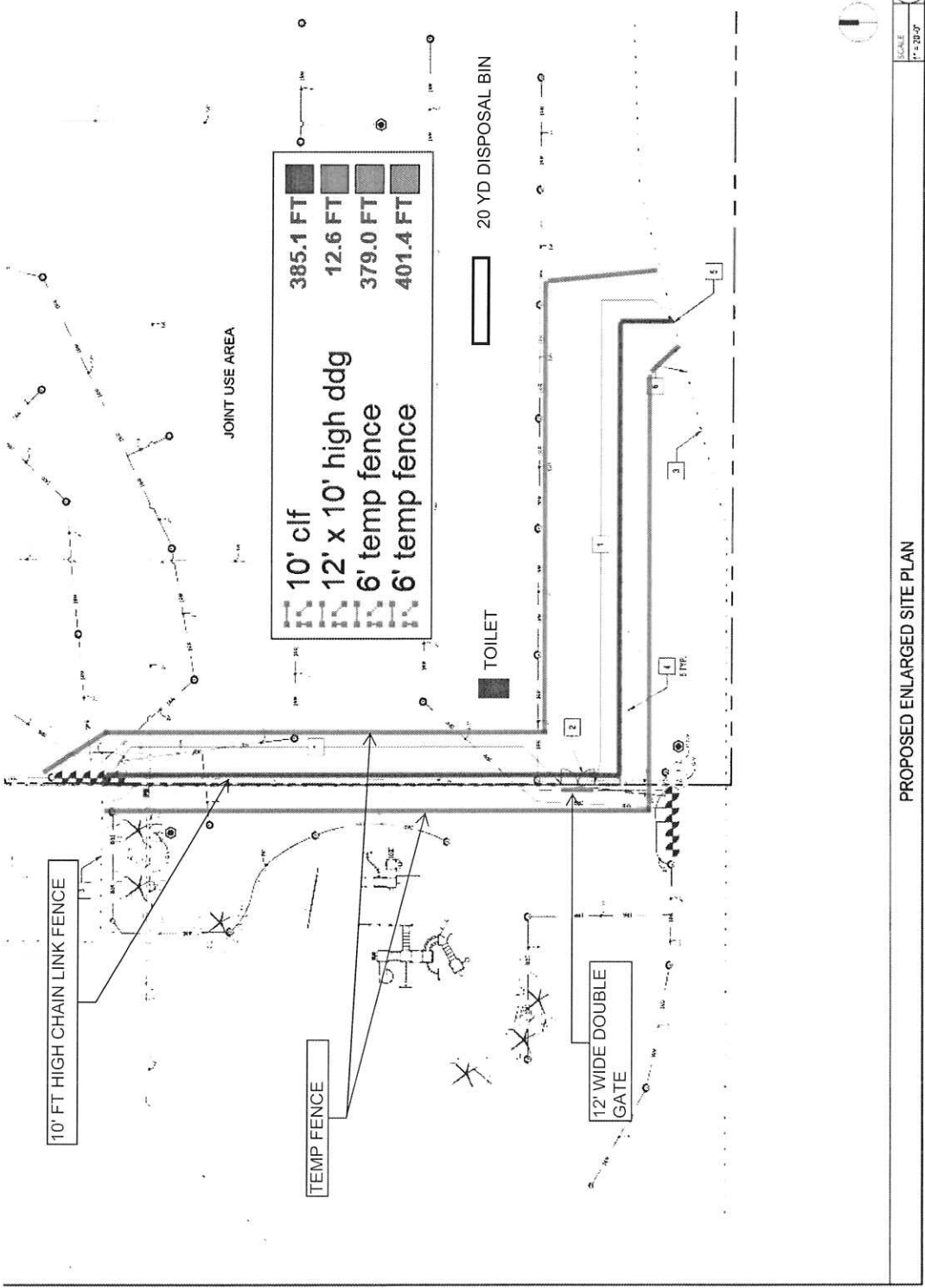

NTP Request (No PO Exists)

 Upper Form

Record Information

Record Number: NTP-000001	Creator: Loren Chico
Project Name: Clay ES JUF Fence	Creation Date: 06/19/2019 10:27 AM (UTC-8)
Project Number: 90650052	Status: Approved
	Record Last Update Date: 07/08/2019 10:17 AM (UTC-8)

NTP Information

Peoplesoft PO Number:
PS Requisition ID:
Title: Clay ES JUF Fence
NTP Number: NTP 02 Clay ES
Estimated Task Order Amount: \$47,041.10

Contract Details

Reference Contract: CON-000257	Effective Date: 01/22/2019 05:00 PM (UTC-8)
Contract Number: CZ19-0619	Expiration Date: 01/21/2020
Contract Title: JOC Fencing Services	
Contract Type: JOC	
Vendor Name: Ferreira Construction Co Inc	Full Contact Name:
Doing Business As (DBA): dba Ferreira Coastal Construction Co	E-Mail:
Vendor ID: 0000037252	

NTP Processing (Informational Only)

Contract Specialist: Mayra Flores
FPC Director / PPO: Gary Stanford
PPO Lead:

Job Order Contract (JOC) Required Fields

To activate these fields, verify a JOC Contract has been selected above.
Is a completed Job Order Cost Evaluation PDF attached and does it demonstrate the contractor's proposed fee for this project is reasonable and cost effective?: Yes
Is contractor's complete list of employees and signed background check certification statement attached?: Yes
Is contractor's complete list of subcontractors and signed certification statement attached?: Yes
Is contractor's proposal attached and is it complete and accurate?: Yes

Task Order Description

Description: Installation of approx. 385 lf. of 10' ft. chain link fencing on District portion of existing Joint Use Field on Clay ES. Project includes installation of 6ft. wide, 10ft. high double leaf access gate.

Justification: Safety and security

Task Order Location

Proposed Task Order Start Date: 06/28/2019

Final Task Order Start Date: 07/18/2019

Proposed Task Order End Date: 08/16/2019

Final Task Order End Date: 08/06/2019

Original Completion Date: 08/06/2019

Project Costing Data

Business Unit: SDUSD

Peoplesoft Activity ID: (H) Construction

Project Name: Clay ES JUF Fence

Project Costing Resource: SVCS

Project ID: 90650052

Budget Journal (PS)

Budget Transfer Journal: 427471

Ledger Group:

Budget Journal: 427475

Budget Period:

 Task Details

Record has been closed.

Workflow Progress

Step Name	Assignee	Company	Status	Action	Completion Date
Creation (PM, SpPM, CM)	Loren Chico	SDUSD	Completed	Request NTP	06/19/2019 10:27 AM
01 Contracts Specialist	Mayra Flores	SDUSD	Closed	Return to Creator for Revision	06/20/2019 07:46 AM
01x Creator Revision	Loren Chico	SDUSD	Closed	Return to Contracts Specialist	06/20/2019 02:15 PM
01 Contracts Specialist	Mayra Flores	SDUSD	Closed	Return to Creator for Revision	06/20/2019 03:24 PM
01x Creator Revision	Loren Chico	SDUSD	Completed	Return to Contracts Specialist	06/20/2019 03:27 PM
01 Contracts Specialist	Mayra Flores	SDUSD	Completed	Send to CSE	06/20/2019 03:30 PM
02 CSE	Cindy Ibarra	SDUSD	Completed	Send to Supervisor	06/21/2019 10:02 AM
03 Supervisor	Kevin Ohlin	SDUSD	Completed	Send to Director	06/21/2019 10:08 AM
04 Director	Gary Stanford	SDUSD	Completed	Send for Funding	06/21/2019 10:13 AM
05 Lead CSE	Greg McFarlane	SDUSD	Closed	Send to Budget Analyst	06/21/2019 04:00 PM
06 Budget Analyst	Linda Balvaneda	SDUSD	Closed	Return to Controls	06/27/2019 12:20 PM
05 Lead CSE	Greg McFarlane	SDUSD	Completed	Send to Budget Analyst	07/01/2019 10:54 AM
06 Budget Analyst	Linda Balvaneda	SDUSD	Completed	Send to Contracts Specialist	07/03/2019 02:28 PM
07 Contracts Specialist	Mayra Flores	SDUSD	Completed	Send to Contracts Supervisor	07/08/2019 09:52 AM
08 Contracts Supervisor	Graham Champion	SDUSD	Completed	Approve	07/08/2019 10:00 AM
09 CS Add Pplsoft Fields	Mayra Flores	SDUSD	Completed	Close NTP, Create Unifier PO	07/08/2019 10:17 AM

 **Standard**

1 Item(s)

No.	Budget String	Code Name	Short Description	Amount	Fund-Resource Code Name	Line Type (for IDIQ)
001	9065-90503-00-6200-8500-0000-21500-8612	Y.FPC Construction	NTP 02 Clay ES	\$47,041.10	Measure YY - 90503	Base Item

Total Amount \$47,041.10

 **Record - General Comments**

6 Item(s)

Comment Date	Created By	Company
06/19/2019 10:26 AM (UTC-8)	Loren Chico	SDUSD
<p>Comment Text</p> <p>Good morning: I was informed either you or Linda weekly process these NTPs. I had a 50/50 chance so you have first right of refusal for this JOC NTP. :-)</p>		
06/20/2019 07:46 AM (UTC-8)	Mayra Flores	SDUSD
<p>Comment Text</p> <p>Loren, The estimated task amount of \$47,041.10 matches the proposal. The line items added at the bottom of the request have a total of \$64,632. Can you confirm I can remove this amount and update to the correct total? Thanks, mf</p>		
06/20/2019 02:14 PM (UTC-8)	Loren Chico	SDUSD
<p>Comment Text</p> <p>This is fine. This is for the budget I set up for the task. If you need to remove the items to move this forward, please do. Thank you.</p>		
06/20/2019 03:24 PM (UTC-8)	Mayra Flores	SDUSD
<p>Comment Text</p> <p>Loren, I am not able to edit the task order amount. Can you please increase by \$.10 to match the proposal (\$47,041.10). I can then send forward for approvals. Thank you, mf.</p>		
06/20/2019 03:27 PM (UTC-8)	Loren Chico	SDUSD
<p>Comment Text</p> <p>Done!</p>		
06/27/2019 12:20 PM (UTC-8)	Linda Balvaneda	SDUSD
<p>Comment Text</p> <p>Funds are available; please re-submit 7/1 for budgeting.</p>		

**Attachments (4)**

**Linked Records (0)**

**Linked Mail (0)**